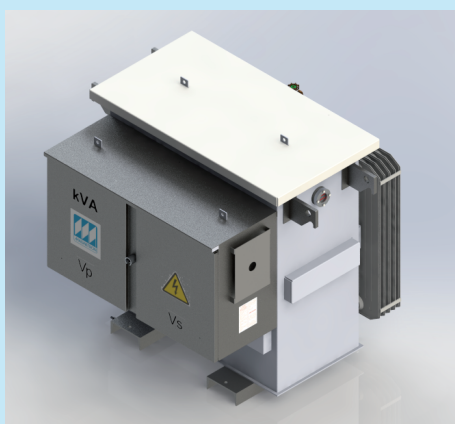

Application:

The electrical submersible pump (ESP) system is intended to lift large volumes of fluids in an efficient and cost-effective manner. Several variables in the lifting process affect the production level. The variable speed drive (VSD) enables the operator to control performance of the ESP system, changing the speed of the motor installed at the bottom of the well, by making changes in the frequency.

Fluid production at the surface is affected to a large extent by the motor operation. Motors installed at the bottom may generate a maximum torque depending on the voltage applied to their terminals at a given frequency. Due to the differences in fluid properties, it is necessary to vary the motor speed in order to obtain the maximum torque; this is achieved by modifying the voltage applied at the motor terminals. This is one of the reasons for using VSD in ESP systems.

Typically, VSD output voltages are lower than those required by the ESP system motor for optimal operation. In addition, since the VSD operating frequency varies depending on the well characteristics and, given that the VSD wave contains harmonics, use of a conventional transformer is not possible in these cases. For these reasons, a special step-up transformer must be used.

**Scope of the offer:**

Manufactured in accordance with applicable ANSI, IEC and NTC standards and/or specific customer specifications.

Volt/Hz Ratio (V-boost)

10.67

Factor K

2, 4, 6, 9, 12, 20.

Product Description

The Magnetron ESP-SUT has been specifically designed for electric-submersible pumping of oil, combining Magnetron's extensive expertise in transformer design and manufacture, with the advanced technology of the main ESP Service Providers, resulting in a perfectly matched team to address and meet the technical and economic needs of the oil industry.

Typical construction mode:

Transformers typically consist of an active part made up of the core (magnetic circuit), the coil (electric circuit) and the yoke clamp, which is determined in accordance with the type of transformer, and placed in a tank that provides the equipment with specific features, depending on its intended application.

Coils:

Concentric circular or rectangular sections with copper or aluminum windings.
Insulation: High-quality paper with epoxy resin coatings.

Cores:

Shell Type or Core Type, wound or stacked, set up in groups for easy assembly and disassembly without loss of dimensional characteristics, guaranteeing low losses and excitation currents.

Materials: Cold-rolled grain-oriented silicon electrical steel sheet with insulating coating on both sides, low core loss and high permeability.

Yoke clamps:

Made of cold-rolled and hot-rolled steel, they clamp the core, with individual bolted caps enabling easy disassembly for maintenance purposes.

They ensure high resistance to short circuit mechanical stresses, low noise levels and low excitation currents.

Tanks:

Rectangular in shape, made of cold-rolled or hot-rolled steel plates with reinforcements capable of withstanding internal pressures due to temperature rise and mechanical stresses due to equipment installation and handling. Three-phase TANKS include a cabinet that is studded or welded to the transformer and serves as protection for the Low Voltage and Medium Voltage circuits, with a mechanical locking system which, for safety reasons, prevents opening of the compartments without the appropriate key.

ITEM	DESCRIPCION	CANT
1	Primary insulator	3
2	Secondary insulator	6
3	Tap changer	2
4	Pressure relief valve	1
5	Tank grounding	2
6	Electrostatic screen grounding	1
7	Lifting lugs	4
8	Oil level	1
9	Fill valve	1
10	Drain valve	1
11	Oil thermometer	1
12	Electrostatic shield insulator	1
13	Nameplate	1

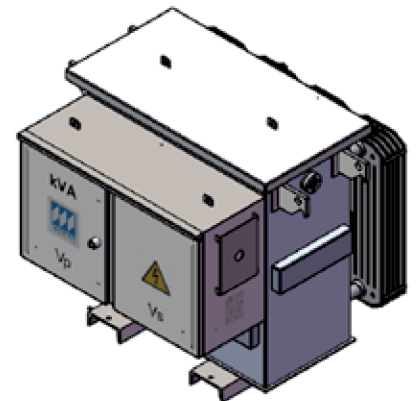
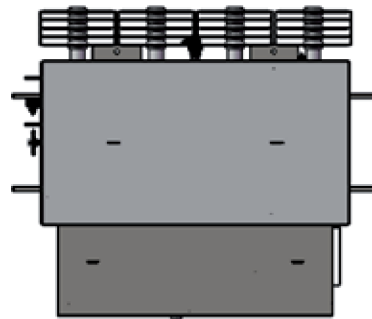

MAGNETRON

