

**Instruction manual for packaging, transport, handling,
installation, storage and maintenance of single-phase
distribution transformers immersed in insulating liquid \leq
500 kVA**





Content

1. Safety and risks	4
1.1 Personal security	4
1.2 Types of risks	4
2. Introduction	7
3. Definitions	8
3.1 Transformer	8
3.2 Primary winding	8
3.3 Secondary winding	8
3.4 Medium voltage winding	8
3.5 Low voltage winding	8
3.6 Packaging	8
3.7 Packing basis	8
3.8 Danger	8
3.9 Risk	8
4. Abbreviations	9
5. Handling	10
6. Packaging	12
7. Transport	13
7.1 Load distribution:	13
7.1.1 Transformers without crate	13
7.1.2 Transformers with crate	14
7.1.3 Load open top trucks	15
7.1.4 Download	17
8. Reception	18
9. Storage	19
10. Basic accessories	20
10.1 MV Bushing	20
10.2 LV Bushing	20
10.3 Overpressure valve	21
10.4 Tap changer	21
10.4.1 Steps to maneuver the tap changer	21
10.5 Nameplate	22
10.6 Grounding system	22
10.7 Lifting Lugs	22
10.8 Internal indication of insulating liquid level	23
10.9 Support to hang on the pole	23
10.10 DPS mounting device	23
10.11 IFD Internal Fault Detector	23
10.12 Temperature indicator (thermometer)	24
10.13 Insulating liquid level indicator (level)	24
10.14 Drain valve	25
10.15 Lid lifting devices	25



11. Terminal marking.....	26
11.1 Polarity	26
11.2 NTC standard marking and polarity.....	27
11.3 ANSI standard marking and POLARITY	27
12. Review and tests before installation.....	28
12.1 Revision.....	28
12.2 Tests	28
12.2.1 Transformation Ratio (TTR)	28
12.2.2 Resistance of the MV and LV windings.....	30
12.2.3 Insulation resistance	30
12.2.4 Insulating liquid tests.....	32
13. Installation and commissioning.....	35
13.1 Pole mount.....	35
13.2 Grounding system	36
13.3 Connection sequence.....	37
13.4 Commissioning.....	37
13.4.1 Energizing transformers with vegetable oil at temperatures below -20°C	37
13.4.2 Energizing transformers with mineral oil at temperatures below -20°C.....	39
14. Transformers with two or more months in storage	40
15. Maintenance	42
15.1 Preventive maintenance.....	42
15.2 Corrective maintenance.....	43
16. Repair	44
17. Problems and possible solutions	45
18. Tightening torques.....	47
18.1 Screws in general	47
18.2 Adjustment screw Cover-Tank.....	47
18.3 MV and LV bushings	47
18.4 Tap changer	47
18.5 Overpressure valves	47
19. Environment.....	48
20. Warranty terms and conditions	50
21. Contact Us.....	51



1. Safety and risks

Please read this instruction manual carefully before servicing the product, disregarding the instructions may result in property damage, serious injury or death.

The product covered in this manual must be operated only by qualified personnel.

This manual contains important information for the safety of personnel and the product.

If any problem not covered in this manual occurs, contact MAGNETRON S.A.S.

When working with transformers, operators are exposed to a series of risks and dangers, it is very important to know them in order to eliminate or minimize situations or conditions that may cause damage.

1.1 Personal security

- Stop any activity if working conditions are unsafe.
- All team members must know the instructions in this manual, the safety practices established in the workplace and the applicable legislation.

- Use clothing and personal protection elements according to the work to be carried out.

- ✓ Long-sleeved cotton shirt.
- ✓ Dielectric safety boots.
- ✓ Bait or dielectric gloves.
- ✓ Latex gloves (taking samples of the insulating liquid).
- ✓ Latex gloves (Handling tools).
- ✓ Safety glasses.
- ✓ Dark glasses for sun protection (field activities).
- ✓ Helmet.
- ✓ Avoid wearing loose clothing.
- ✓ Do not wear rings, watches, chains, earrings or any personal item that could cause harm.
- ✓ Do not wear tennis shoes, shorts, short-sleeved shirts, and headphones.

1.2 Types of risks

➤ physical risks

It refers to all environmental factors that depend on the physical properties of the bodies and that act on the tissues and organs of the worker's body, can produce harmful effects according

to their intensity and exposure time.

They are related to the imminent probability of suffering bodily harm with or without direct contact, they can be classified as labor or environmental.

The most common and dangerous conditions at work:

- ✓ Noises,
- ✓ Lightning,
- ✓ Temperature,
- ✓ Humidity,
- ✓ radiations,
- ✓ vibrations,
- ✓ Electricity.

Listed below are some activities that must be carried out:

- Install localized lighting in those jobs that require it, when general lighting is moderate and may be insufficient.
- Avoid dead flow areas (where air does not flow freely).
- Use work equipment that generates low noise levels.
- Locate noisy equipment or sources out of the way, if possible.
- Reduce the exposure time.
- Establish a shift rotation system on field.

- Use screens or protective shielding, for radioactive sources.
- Apply the 5 golden rules when working with energy.

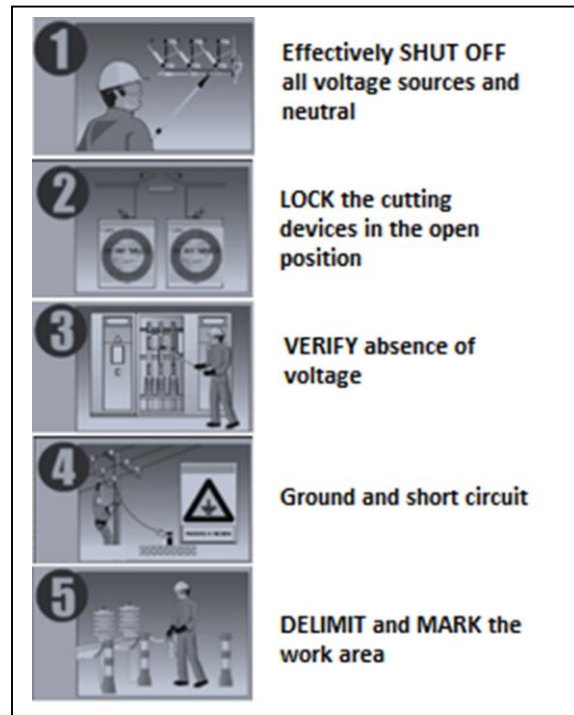

Figure 1: 5 golden rules

➤ Mechanical risks

They are associated with the set of physical factors that can give rise to an injury due to the mechanical action of machine elements, tools, work pieces or projected, solid or fluid materials.

The mechanical risk can occur in any operation that involves manipulation of hand tools, machinery, handling of vehicles, use of lifting devices, such as:

- ✓ collision with moving or stationary objects,
- ✓ Hits,
- ✓ Cuts,
- ✓ Entrapments due to overturning of machines or vehicles,
- ✓ Entrapments by or between objects,
- ✓ Projection of fragments or particles,
- ✓ Falling objects being handled.

Listed below are some activities that must be carried out:

- Train workers in preventive matters, both in theoretically and practically related to the work equipment necessary for their job.
- Guarantee the conditions and correct way of using machinery, based on the manufacturer's instructions.
- Promote the consultation and participation of workers in aspects related to mechanical risks.
- Guarantee periodic monitoring of the health status of workers.
- In the event of accidents or occupational diseases due to mechanical risks, the necessary corrective measures must be investigated and applied so that it does not happen again.



Figure 2: Signs of mechanical risk



2. Introduction

Read carefully and comply with the indications given in this manual before any intervention on the product, failure to comply with them invalidates the guarantee.

The electrical transformer is a noble, simple and safe electrical device that has accompanied us in daily life since the beginning of electrical engineering, faithfully fulfilling its mission of transforming electrical parameters.

The Single-Phase Liquid Immersed Transformer is designed to reduce distribution line voltage to voltages that can be handled with a low risk to end users.

Its useful life depends, among other reasons, on the following:

- Manufacturing design,
- Supply voltage,
- The connected load,
- The protections used,
- The level of the insulating liquid,
- The maintenance received.

The use of the transformer plays a very important role in the electrical supply. A failure in its operation can generate enormous inconveniences for companies, the industry or the population, since everyone uses the electrical service equally in their daily activities.

The information, recommendations, descriptions and safety notes compiled in this document are based on guides, standards and the experience of MAGNETRON S.A.S.

This information does not include or cover all contingencies, therefore, if you require more information, contact MAGNETRON S.A.S.



3. Definitions

damage to health that such an event can cause.

3.1 Transformer

Electrical device without moving parts that transforms electrical energy into its two main factors: Voltage and Current.

3.2 Primary winding

Winding that is connected to a power source.

3.3 Secondary winding

Winding to which a load is connected.

3.4 Medium voltage winding

Winding with the highest voltage.

3.5 Low voltage winding

Winding with the lowest voltage.

3.6 Packaging

Cover normally made of wood in which transformers are packed during storage and transport.

3.7 Packing basis

Flat and strong structure manufactured usually in wood that serves to protect and support the weight of the transformer.

3.8 Danger

Inherent situation with the capacity to cause injury or damage to people's health.

3.9 Risk

Combination of the probability that a dangerous event will occur with the seriousness of the injuries or



4. Abbreviations

ANSI	American National Standards Institute
ASTM	American Society for Testing and Materials
MV	Medium voltage
LV	Low voltage
DPS	Device for surges (lightning rod), source arresters
kg	Kilogram
kV	Kilovolt
kVA	kilo volt amps
lbf.ft	pound-force foot
m	Meter
max	Maximum
min	Minimum
mΩ	Milliohms
MΩ	Megohms
more	Milliseconds
ntc	Colombian technical standard
PCB's	PCBs
Np	Neutral point
psi	Pounds per square inch
PTS	Grounding system
Grd	Grounding
VSP	Overpressure valve

5. Handling

Caution: The transformer must be handled in a vertical position.

Keep the transformer on the base on which it is shipped to the site where it will be installed, since it provides greater protection.

Do not allow the transformer to be dragged directly on the ground for any reason, the tank could suffer deformations or the paint could deteriorate, resulting in the oxidation of the sheet metal.

The transformer must not be lifted or moved by holding it by the medium or low voltage bushings or by any accessory that is not the lifting lugs, since they are very fragile parts and can suffer damage.

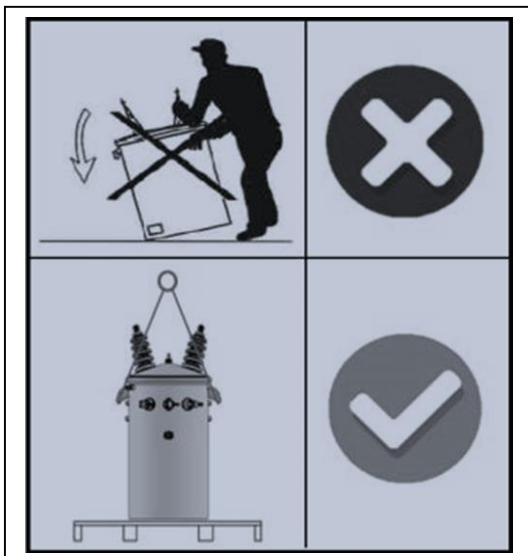

Figure 3: Handling transformers

Do not lift or move the transformer by placing crowbars or jacks under

accessories, connections, radiators or other devices, these elements are not designed to be subjected to this type of stress and may introduce ruptures or deformations causing leaks.

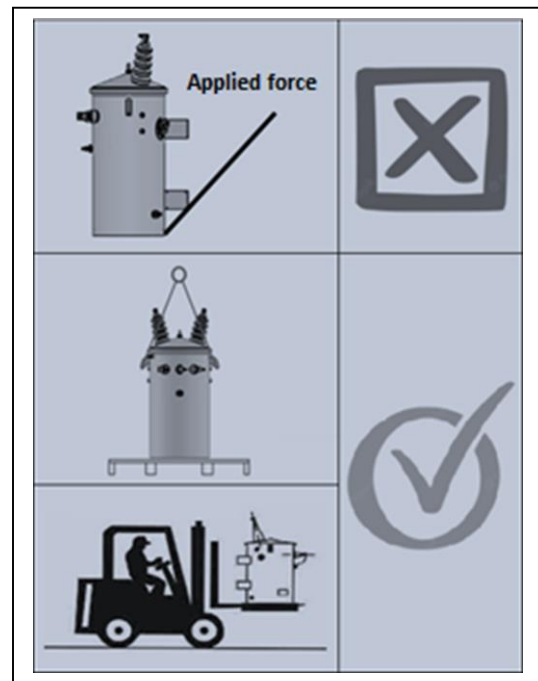

Figure 4: Levers or movements not allowed

When a transformer cannot be handled by means of a crane, differential, lift truck either stowage carrier, you can move it by sliding it on skates or rollers, taking care not to damage the base or drop it.

Use rollers or skates according to the weight of the product and in sufficient quantity to distribute its weight.

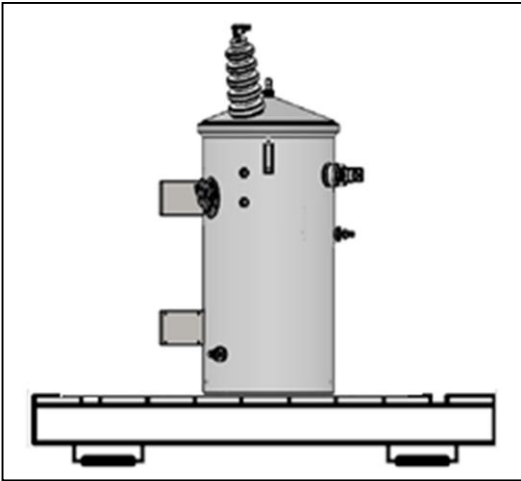

Figure 5: Use of skids for transportation

Transformers are provided with lifting devices or lifting lugs that are used to manipulate them with crane, fiber slings must be used to protect the paint.

If you use strings or metal slings, be sure to cover the parts in contact to avoid paint detachment.

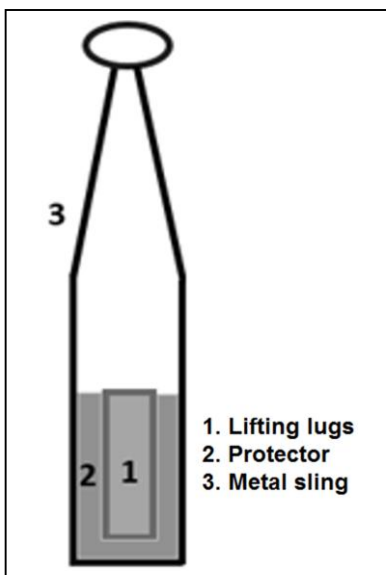

Figure 6: Paint protection on the lifting lugs

Do not use the lifting lugs to transport the transformer, these devices are designed only for lifting the transformer.

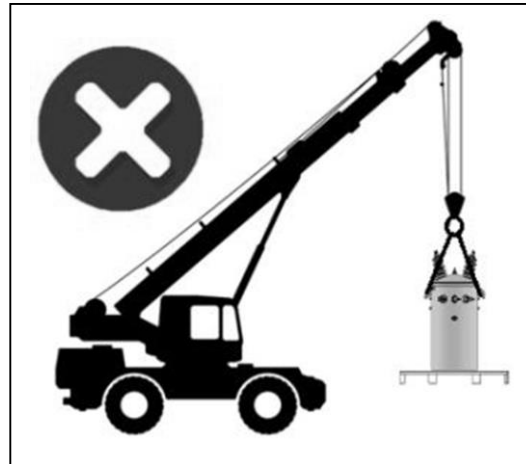

Figure 7: Transport of the transformer by the lifting lugs is prohibited

6. Packaging

The packaging of a transformer must allow handling in such a way that, when any movement is required for storage or transport, it is easy to lift it by the base of the packaging.

The base of the packaging must have a minimum height of 10 cm to allow the entry of a forklift or a pallet rack.

The transformer must be attached to the base of the packaging to prevent it from suffering damage caused by sudden movements. The coupling can be through straps, wedges in the supports to hang on the pole or by means of screws.

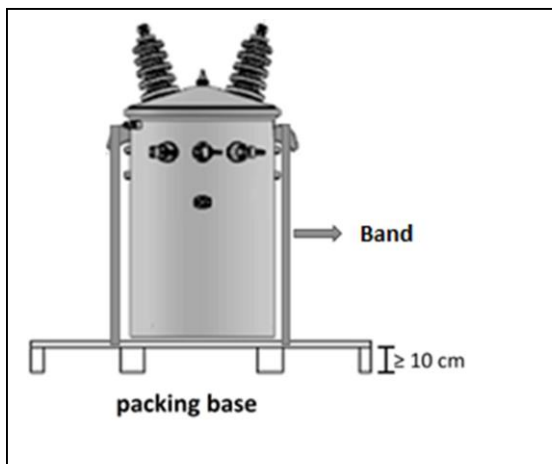

Figure 8: Packing base transformer assembly

The transformer packaging must be arranged in such a way that it does not obstruct access to the information stated on the nameplate, especially when it is packed.

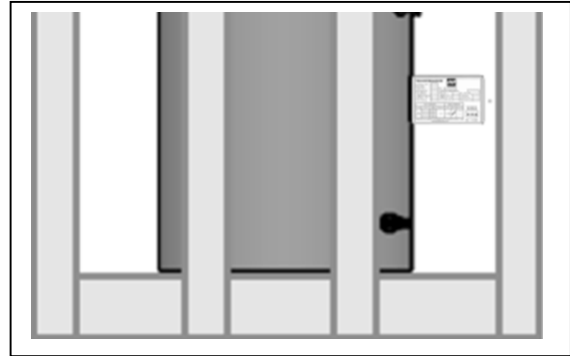

Figure 9: Visible nameplate

7. Transport

Take into account the weight of the transformer to determine the appropriate lifting and/or transport elements, this information appears on the nameplate, in the test certificate or in the documents required for its transport.

Lift the transformer using the lifting lugs or the base of the packaging.

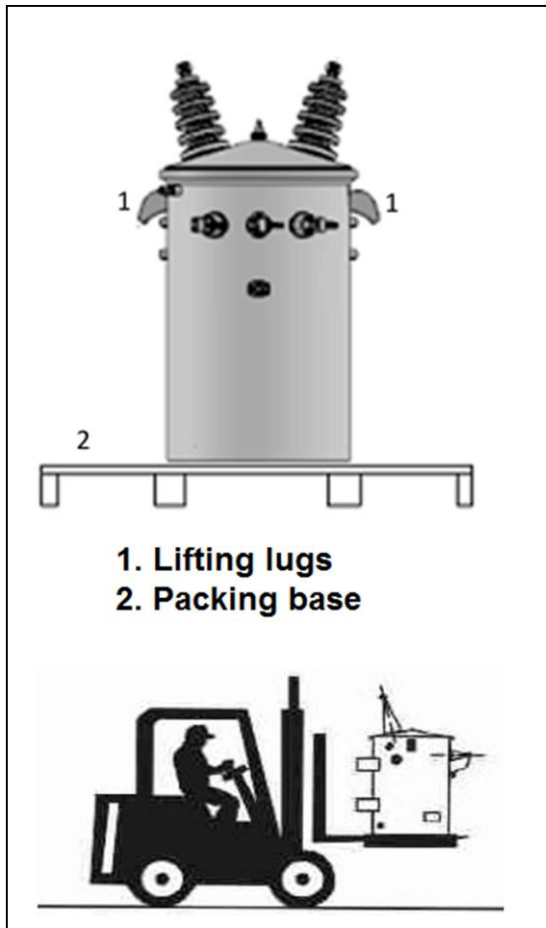

Figure 10: Parts to lift or hoist the transformer

When lifting the transformer from the lifting lugs, be sure not to rub or touch the bushings or any accessories with the slings.

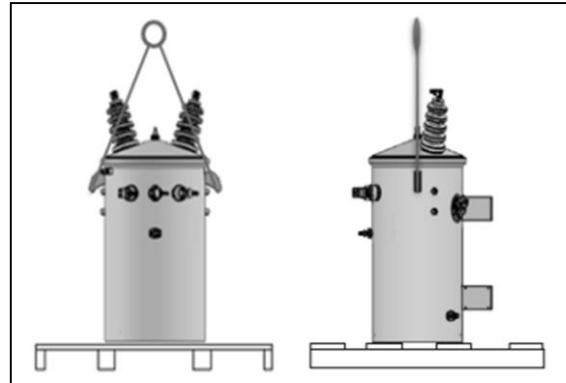

Figure 11: Elevation of the transformer from the lifting lugs

7.1 Load distribution:

7.1.1 Transformers without crate

When a considerable number of transformers are transported, the load must be distributed within the truck or container.

The base of the transformer acts as a separator, when there are spaces between them, wooden wedges must be set between them and the floor.

The function of the wooden wedges is to prevent displacement of the transformers when the transport is in motion.

Additionally, transformers must be slinged to the walls of the truck or container and to each other.

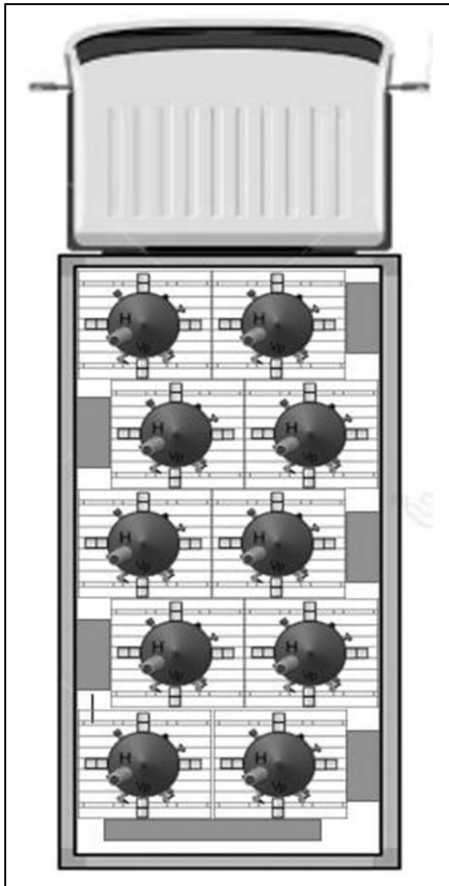

Figure 12: Loading, distribution and use of wedges in transformers

7.1.2 Transformers with crate

When a considerable number of transformers are transported, the load must be distributed within the truck or container in groups separated from each other.

The function of the wooden wedges is to prevent displacement of the transformers when the transport is in motion

The packaging of the transformers acts as a separator, when there are spaces between them,

wooden wedges must be fixed between them and the floor.

Additionally, each set must be tied together to form a solid unit and between them to the walls of the truck or container.

These transformers can be loaded on up to two levels, as long as the weight of the load located on the second level does not exceed 400 kg.

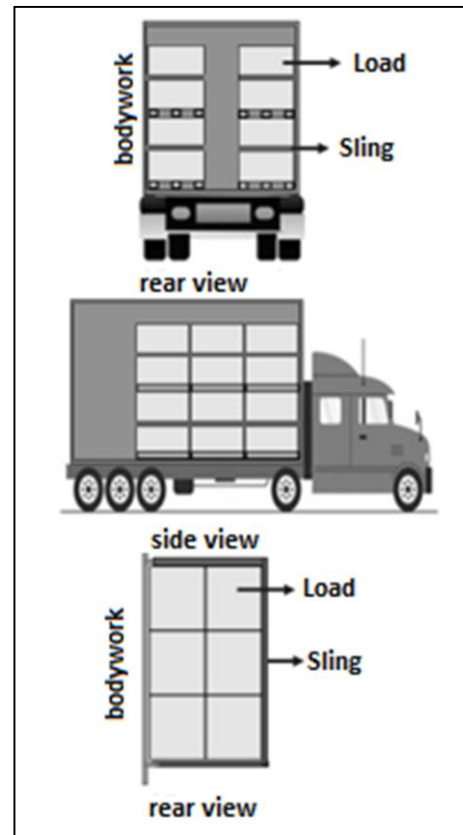

Figure 13: Proper way to load and tie boxed transformers

7.1.3 Load open top trucks

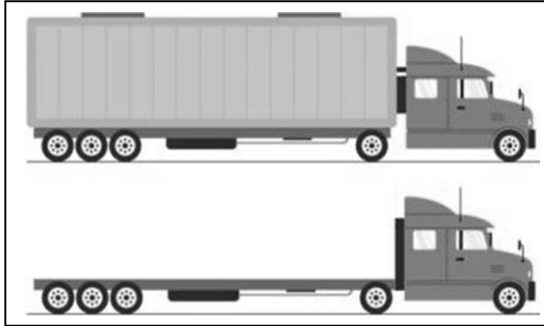

Figure 14: Normal and open top truck

Loading on this type of truck has several advantages:

- By not having the tent, the rod and the sides, a better use is made of the total available area of the plate.
- The load can protrude +/- 15 cm from the sides of the plate.

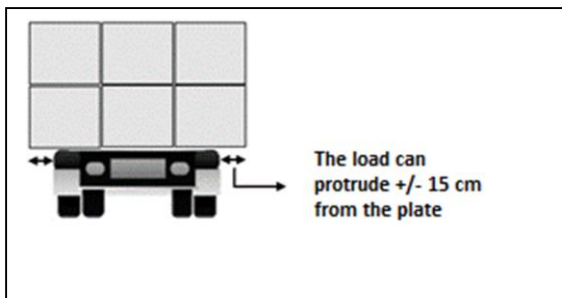

Figure 15: Load tolerance on the sides of the plate

- The total number of transformers in the load is increased.
- Reduces freight costs.

- Loading and unloading is done on the sides of the truck, reducing the times for these activities.
- When loading crated transformers, they can be stacked up to two levels, as long as the weight of the transformers on the second level does not exceed 400 kg.

Caution: For Colombia, the total height of the load, measured from the floor, cannot exceed 4.3 m.

The total weight of the load cannot exceed the capacity of the truck.

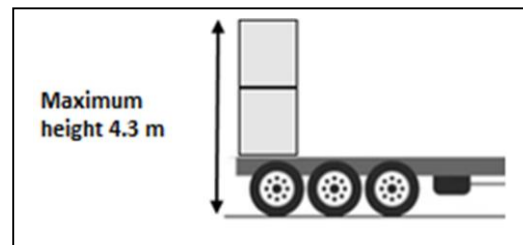

Figure 16: Maximum loading height

➤ Steps for loading

- Loading must be done from the front of the plate (near the cabin) to the back of it.
- With the help of the appropriate mechanical means (forklift, crane, etc.) load the first row of transformers.
- Once the transformers in the first row are located and aligned, secure them with a sling by attaching the sling to

the truck chassis and passing it over the crates.



Figure 17: Loading and securing the first row

- Repeat the previous numeral until completing the total charge of the vehicle.



Figure 18: Total truck load

- To prevent load shifting during transport, sling the last row of loaded transformers.



Figure 19: Securing the last row of loaded transformers

Precautions: All rows must be secured with slings, these must be well tensioned.

When loading partially on two levels, make sure it is done in the center of the platen.



Figure 20: Two levels in the central part of the plate, load leveling.

7.1.4 Download

Precautions: Some transformers have accessories that lift the lid, NEVER use them to lift the product.

If you use strings or metal slings to lift the transformer, be sure to cover the parts in contact to avoid paint detachment.

The unloading of the transformers is the responsibility of the customer, unless otherwise specified in the contract. However, the following should be noted:

- If you have doubts about the gross weight of the product, the lifting elements to be used, the method to unload the product or any other activity, refrain from maneuvering and contact MAGNETRON SAS
- Always use the appropriate mechanical means, forklift, crane, etc.
- The mechanical equipment used must have at least twice the capacity of the weight of the product.
- Lift the transformer only by the lifting lugs or the bottom of the packaging.
- Personnel involved in the downloading must stay away from the transformer when it is lifted.

- Transformers loaded in open top trucks must be unloaded in opposite way to loading.
- In containers or trucks with close container, the transformers that are out of reach must be pulled until they are placed in the unloading position, to do this:
 - Attach a sling to the hoist or mechanical means used and pass it around the base of the transformer packaging.
 - Pull the transformer until it is within reach of the mechanical means used.
 - Download the transformer.

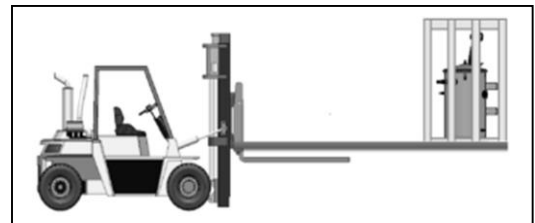

Figure 21: Proper way to pull a transformer in the download

8. Reception

Caution: Before downloading the transformer, should visually inspect the state of the same, any abnormality communicates it to the transporter and leave a record of it.

The transformers covered in this manual are factory tested according to standards, they are delivered fully assembled and ready for installation, however, taking into account the difficulties that arise during transportation, the following must be taken into account:

- Check that the security seals located between the lid and the tank have not been removed or show evidence of having been tampered with.

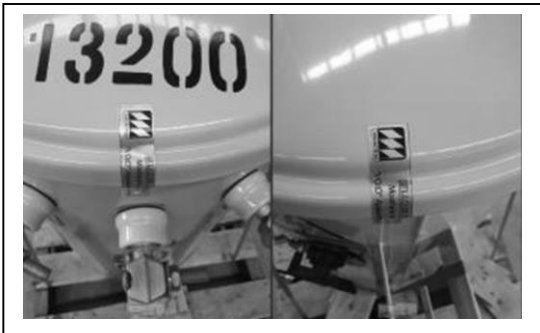

Figure 22: Security seal

- Check the condition of the other accessories that are part of the transformer (overpressure valve, source arresters, etc.).
 - Check that there are no insulating liquid leaks.
 - Inspect the base (wood or metal), it should not show damage.
 - Check that the characteristics of the transformer correspond to what was requested (power, phases, voltages, serial number, etc.).
 - In case of finding damage to the transformer, if possible, leave a photographic record of the findings.
 - Inform the transporter of the abnormalities found.
 - Contact MAGNETRON S.A.S. and notify what happened, supplying the complete information of the transformer.
 - Keep in mind what is established in numeral 7 "Transportation" before unloading the transformer.
- Check the state of the MV and LV bushings, they should not be loose or present damage.
 - Check the state of the tank, it should not show bumps, cracks or damage to its paint.

9. Storage

Caution: Keep the transformer in the packaging (base or crate), this protects it from damage or deterioration during storage.

Caution: To prevent moisture from entering the transformer, the overpressure valve **MUST NOT** be actuated for any reason.



If the transformer does not require immediate installation, observe the following instructions to ensure its good condition:

- Store it indoors.

Note: If storage is done outdoors, keep in mind that environmental conditions can deteriorate the base or crate, thereby causing damage or deterioration of the transformer.

- Do not store it in places where there is presence of moisture, sludge, corrosive gases or explosive atmospheres.
- The storage of the transformers depends on their size and their packaging. If the transformer is crated and the power is less than or equal to

100 kVA, they can be placed on two levels (one above the other) at most.

Note: If storage is done outdoors, they cannot be placed on two levels (one above the other).

- Transformers with power greater than 100 kVA must be stored in units.
- Do not store transformers on two levels (one on top of the other) when storage is longer than six (6) months.
- When storage is extended for more than six (6) months, has to periodically inspect the state of the base or crate.

10. Basic accessories

Caution: If any accessory is not covered in this manual or requires more information, contact MAGNETRON SAS

The accessories described in this numeral obey the basic accessories that are part of a single-phase transformer, however, reference is made to some protection or control accessories.

Also, it is worth clarifying, there are many references for each type of accessory, only reference is made to the accessory as such.

10.1 MV Bushing

Accessory, normally made of porcelain, designed to mechanically hold the conductors that are part of the power line, keeping them isolated from earth and other conductors.

Its main function is to make the bridge between the medium voltage terminals of the active part and the power supply.

Its characteristics vary according to the voltage level of the transformer, the basic level of insulation and the creepage and arc distances.



Figure 23: MV Bushings

10.2 LV Bushing

Accessory, normally made of porcelain, designed to mechanically hold the conductors that are part of the power line, keeping them isolated from earth and other conductors.

Its main function is to make the bridge between the low voltage terminals of the active part and the external load.

Its characteristics vary according to the voltage level of the transformer, the basic level of insulation and the creepage and arc distances.

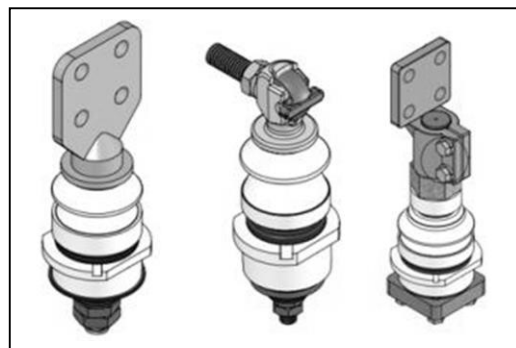

Figure 24: LV Bushings with their respective terminals

10.3 Overpressure valve

Located at the top of the tank, near the LV. It is used to relieve the internal pressure of the tank when it exceeds the safe operating limits.

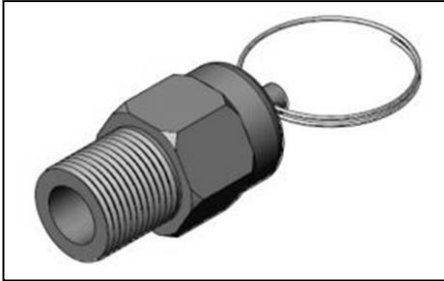

Figure 25: Overpressure valve

Note: It must not be operated manually, doing so implies the entry of moisture (water) into the transformer.

10.4 Tap changer

Caution: The switch has an external handle, which must be operated only with the transformer de-energized.

This device allows the transformation ratio to be varied to guarantee that the required voltage is delivered at low voltage.

10.4.1 Steps to maneuver the tap changer

- Disconnect the transformer from the power source.
- Verify the absence of voltage on the transformer by measuring the LV winding with a voltmeter.

- Ground the MV and LV bushings.
- Using a screwdriver, loosen the handle anchor screw until it protrudes from the disc.
- Rotate the handle and bring it to the needed position.
- Re-secure the handle anchor screw, until it enters the disc.
- Remove the grounding connections from the MV and LV bushings.
- Measure continuity at the MV bushings to ensure that the switch is properly engaged.
- Re-energize the transformer.
- Measure the voltage on LV, confirm that it is the desired voltage.

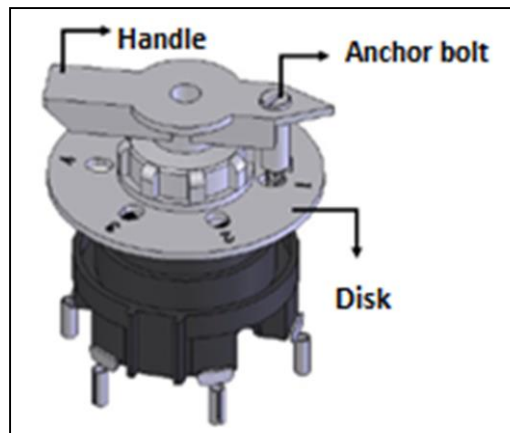

Figure 26: Tap changer switch

10.5 Nameplate

It is an accessory made of a material resistant to corrosion (aluminum, stainless steel, etc.) where the most relevant information on the transformer is recorded.

The plate must be fixed in a visible place and its inscriptions must be legible and indelible.

SERIE No		486889		TRANSFORMADOR	
AÑOS	22/10		ALTA	1000	
FASES	1		50 kVA	CALENT. ACEITE	60 °C
TENSION PRIM.	13.2 kV		CALENT. DEV.	65 °C	
TENSION SEC.	240/120 V		CORRIENTE PRIM.	3,79 A	
T. S. - BIL. AT/ST	15/1.2-95/30 kV		CORRIENTE SEC.	208,33 A	
FRECUENCIA	60 Hz		MAT. DEVANADOS	Al/Al	
CLASE	AN		% Zcc A 85°C	2,49	
REFRIGERACION	ONAN		CORRIENTE CC	8,37 kA	
POLARIDAD	SUSTRATIVA		DURACION CC	0,78 s	
TAP	Vp (VOLTIOS)		PESO TOTAL	255 kg	
1/A	13530		ACEITE MINERAL	58 L	
2/B	13200		INSTRUCTIVO	F-MKT-01.	
3/C	12870				
4/D	12540				
5/E	12210				

FABRICADO EN PEREIRA, COLOMBIA. POR MAGNETRON S.A.S. PLANO. 23

Figure 27: Example nameplate

10.6 Grounding system

The transformer is provided with two screws with their respective accessories to allow:

- The low voltage neutral point grounding to the tank, it is shipped connected from the factory.
- The grounding of the tank to the grounding system where the transformer will be installed.

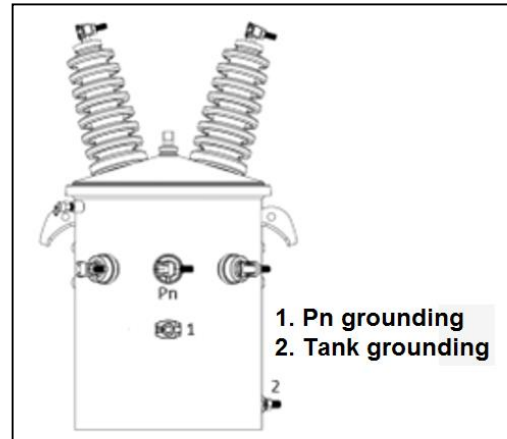

Figure 28: Grounding points

10.7 Lifting Lugs

Devices for lifting or hoisting the fully assembled transformer and filled with insulating liquid, that are located in such a way that when hooking the straps or slings they do not lean against other accessories, nor against the bushings, nor do they damage the cover.

They are used for hoisting or lifting only, not for transporting.

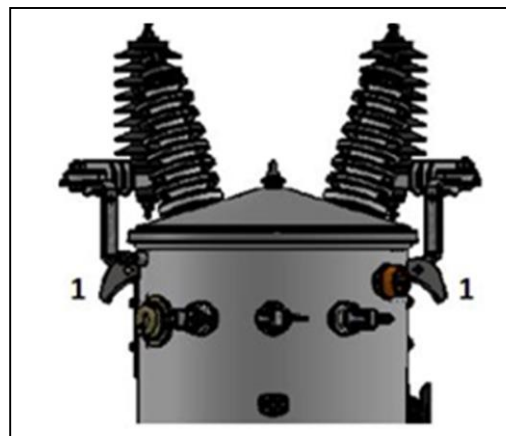

Figure 29: 1. Lifting lugs

10.8 Internal indication of insulating liquid level

Internal marking that is made by paint or other indelible marking in a place visible to the user when the transformer is uncovered.

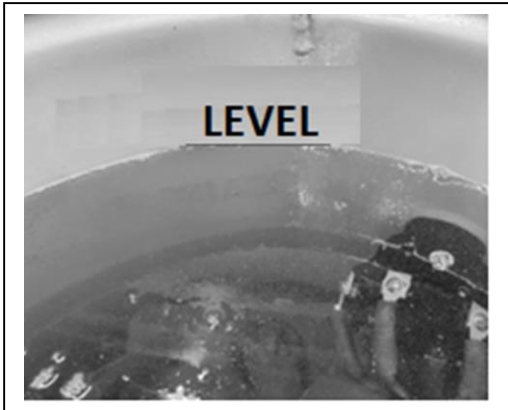

Figure 30: Internal level

10.9 Support to hang on the pole

Devices designed with the size and adequate mechanical resistance to support the transformer completely assembled and filled with insulating liquid and installed on the pole.

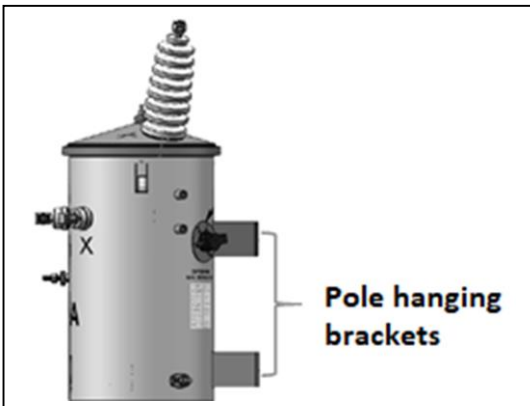

Figure 31: Pole Hanging Brackets

10.10 DPS mounting device

Each transformer has two internally threaded bushings or two studs welded to the tank for each MV insulator, which are used for mounting the SPDs.

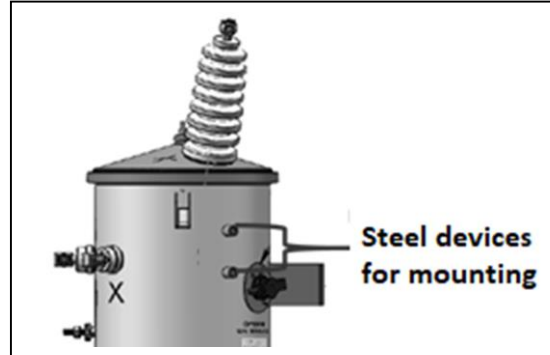

Figure 32: DPS mounting devices

10.11 IFD Internal Fault Detector

The IFDTM is a sensor that detects internal arc faults in distribution transformers, its installation is made to order.

IFD makes it easy to quickly identify the faulty transformer from +/-20m away from the pole.

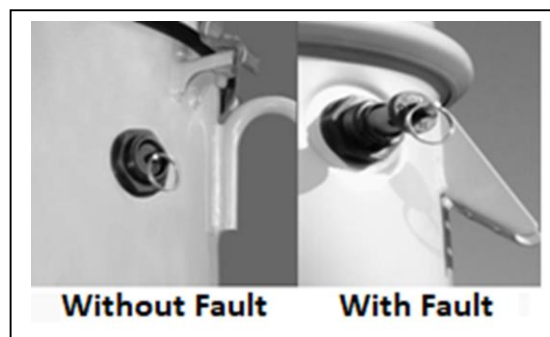

Figure 33: IFD in operation

When an internal fault occurs and the tank pressure rises rapidly at a rate of 0.5 psi for 5 to 7 ms, the IFD signaling device activates, releasing a highly visible orange signal.

The signal alerts the operator or crew so that the transformer is not energized again.

The internal fault detector is equipped with a 10 ± 2 psi relief valve.



Figure 34: Parts of the IFD

10.12 Temperature indicator (thermometer)

It is an instrument that measures the temperature of the liquid in degrees Celsius and includes a resettable maximum temperature indicator.

The red maximum temperature indicator can be reset by turning the magnet in the center of the faceplate towards the white indicator pointer.

The temperature gauge is mounted in a liquid-tight drywell for easy replacement.

As an optional feature, liquid temperature indicators can be provided with one (1) or more contacts to allow remote signaling of unacceptable temperatures or to control cooling fans installed on the transformer.



Figure 35: Temperature indicator

10.13 Insulating liquid level indicator (level)

It is a device or meter that indicates the level of dielectric fluid in the transformer tank.

When the gauge is installed at the factory, the tank is filled to the level that corresponds to a liquid temperature of 25°C.

If the meter indicates a "LOW" fluid level, then the transformer should be de-energized and inspected to determine the cause of the low fluid level. A low level of liquid can cause dielectric failure, overheating of the transformer and a reduction in its useful life.

As an optional feature, the liquid level meter can be provided with one (1) or more contacts for remote signaling of levels (low or high) of dielectric fluid.

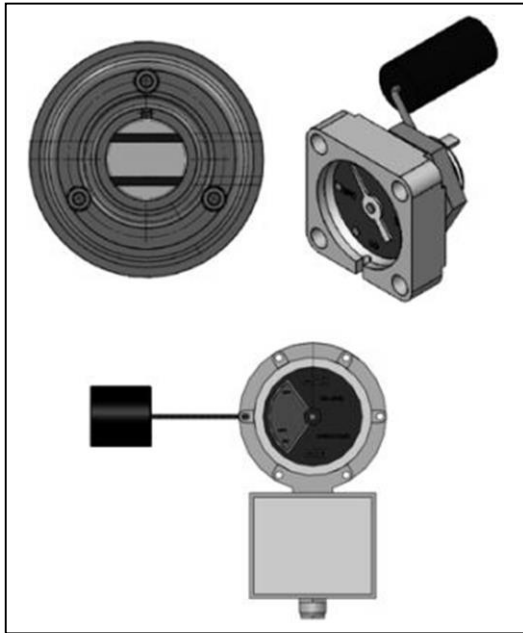

Figure 36: Insulating liquid level indicators

10.14 Drain valve

This device is located at the bottom of the tank, it is used for:

- Take samples of the insulating liquid within order to carry out the physical-chemical tests.
- Drain the insulating liquid if necessary.
- Recirculate insulating liquid when performing field maintenance.

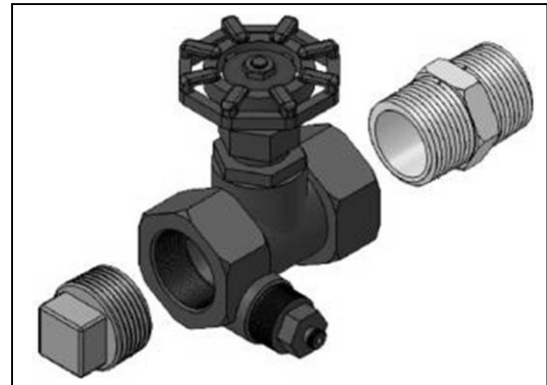

Figure 37: Drain valve

10.15 Lid lifting devices

Devices located on the cover that serve to lift or raise the cover, are not designed to lift the transformer.

When the active part is attached to the cap, the devices are designed to lift the complete lid-active part assembly.

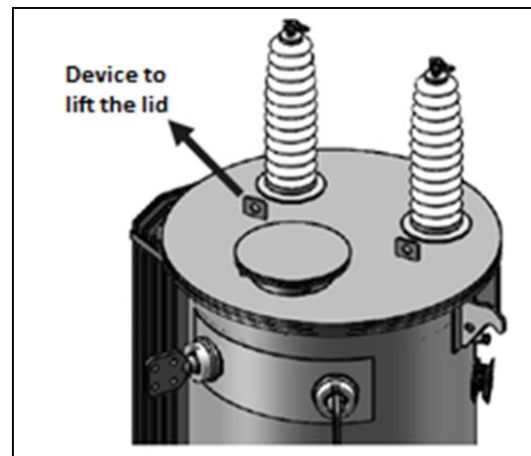

Figure 38: Devices for lifting the lid

11. Terminal marking

The markings of the medium and low voltage terminals in this type of transformers depend on two factors:

- Standard (NTC or ANSI)
- Polarity (additive or subtractive)

11.1 Polarity

The polarity in single-phase transformers is defined by standard (ANSI C57.12.70) as follows:

Any transformer with power ≤ 200 kVA and MV voltage ≤ 8660 V will be ADDITIVE POLARITY, the other transformers will have SUBTRACTIVE POLARITY.

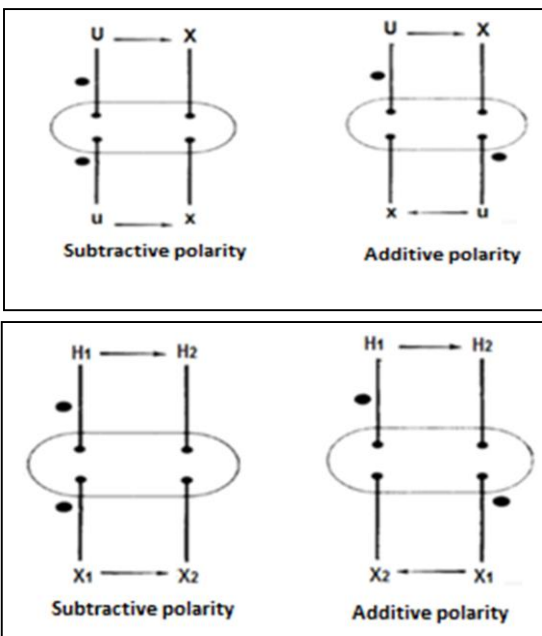

Figure 39: Polarity according to NTC and ANSI

- Examples of polarity according to the characteristics of the transformer

Power (KVA)	Voltage HV	Polarity
5	19920	Subtractive
5	4160	Additive
10	13200	Subtractive
15	13200	Subtractive
25	2400	Additive
37.5	7620	Additive
37.5	10000	Subtractive
50	7620	Additive
75	13200	Subtractive
100	11400	Subtractive
167	2400	Additive
250	4160	Subtractive
250	13200	Subtractive
333	11400	Subtractive
333	2400	Subtractive
500	13200	Subtractive

Notes:

- A transformer can change polarity by customer's request.
- The polarity in single-phase transformers is very important when they are used to assemble three-phase banks.

11.2 NTC standard marking and polarity

- The markings in the MV terminals are made with CAPITAL letters and for the LV terminals they are made with LOWER CASE letters.

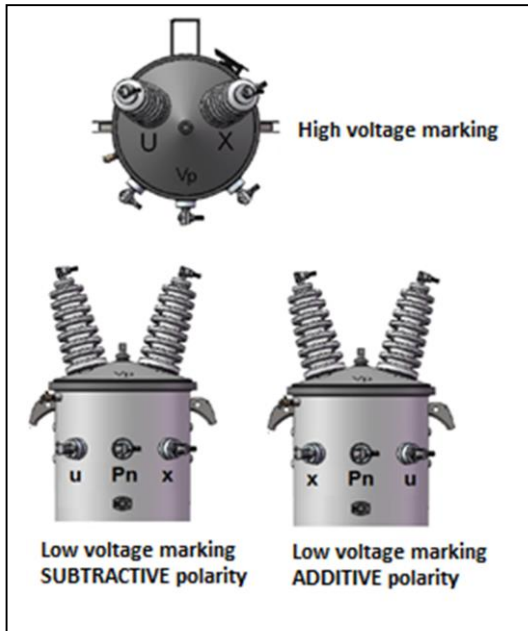

Figure 40: Marking according to NTC

11.3 ANSI standard marking and POLARITY

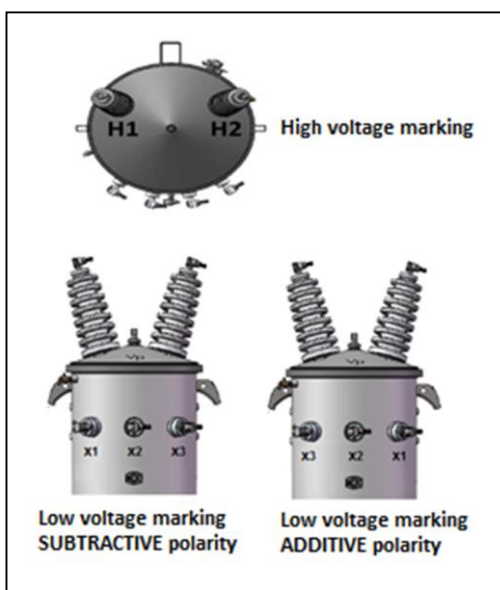

Figure 41: ANSI marking



12. Review and tests before installation

12.1 Revision

Before installing the product, the customer must check the following

- Remove all traces of dirt and foreign material from the MV and LV Bushings.
- Clean transformer tank.
- Check that the accessories are in good condition and properly adjusted.
- Check that there are no insulating liquid leaks.
- Make sure that the transformer does not present blows or damage that could invalidate its proper functioning.
- Review the information on the nameplate and verify that it is in accordance with the requirements (power, voltages, etc.).
- Remove the base and crate (if equipped) from the transformer.
- Verify that the switch is well anchored and in the required position.
- Make sure the low voltage neutral point is properly grounded to the tank.

12.2 Tests

In order to ensure the proper functioning of the product and not affect the warranty of the equipment, the following tests must be carried out to validate the installation and energization of the same:

12.2.1 Transformation Ratio (TTR)

This test is performed to measure the ratio of voltages or turns between two or more windings.

Also, it is a test that allows to identify:

- The connection group.
- Short circuit between turns or layers.
- Failures due to burst or open terminals.
- Damage or bad operation of the commutator.
- Wrong or broken connections.

Depending on the equipment used, the test is performed as follows:

➤ Analog or crank TTR

With this equipment, the ratio of the transformer under test is compared with a reference transformer (internal to the equipment) whose ratio is adjustable in small steps.

The transformer under test and the TTR are connected in parallel applying voltage to the MV windings; the LV windings, in parallel, are connected to a sensitive detector which is forced to signal zero (0) by adjusting the transformation ratio of the reference transformer (TTR). The adjusted transformation ratio of the reference transformer (TTR) is then equal to the transformation ratio of the transformer under test.

This procedure must be carried out in all tap positions and in all phases if it is a three-phase transformer.



Figure 42: Analog or crank TTR

➤ Digital TTR

With this equipment, an adjustable voltage is applied to the MV terminals and the output voltage of the winding corresponding to the LV is measured. The value of the transformation ratio results from the division of these voltages.

The MV and LV terminals of the metering equipment are connected to the MV and LV terminals of the transformer under test according to the marking of the corresponding phases. The equipment must be configured according to the connection group and the voltage to be applied, as standard 8V is used.



Figure 44: Digital TTR

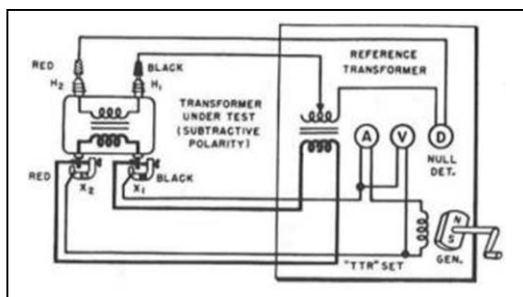

Figure 43: TTR connection to the transformer under test

➤ Calculation of the transformation ratio

They are carried out according to the connection group or the polarity of the transformer:

Phases	Connection type	Formula or calculations
1	li0 - li6	$RT = \frac{\text{Voltage MV}}{\text{Voltage LV}}$

Figure 45: Ecuacion to calculate the transformation ratio

12.2.2 Resistance of the MV and LV windings

This test is performed to ensure that the internal connections of the transformer are not loose or open.

- With an ohmmeter (multimeter) check the high voltage connection, connect the meter between the high voltage terminals (U-X or H1-H2).

When the reading on the meter has stabilized, compare the result obtained with the value stated in the test certificate, there should not be a variation greater than +/- 5%.

- To verify the low voltage connection, connect the meter between the low voltage terminals (u-x or x1-x3).

When the reading on the meter has stabilized, compare the result obtained with the value stated in the test certificate, there should not be a variation greater than +/- 5%.

If, when carrying out the test, any of the following cases occurs, the transformer has suffered internal damage:

- When measuring the MV winding, the value returned it is more or less double that the value it the test certificate.
- When measuring the MV winding, the meter does not record a measurement value.
- When measuring the LV winding, the meter does not record a measurement value or does not record any value.

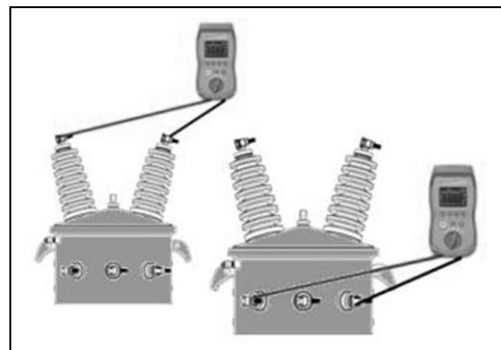

Figure 46: MT and LV winding resistance measurement

12.2.3 Insulation resistance

This test is carried out to have a vision of the state of the insulation in terms of contamination by the presence of water, metal particles or foreign elements suspended in the insulating liquid.

- Use a 5 kV megger with a measurement range of 50 MΩ minimum (use the same factory test voltage to minimize drift.)
- Test for one (1) minute for each measurement (MV vs LV, MV vs Grd, and LV vs Grd).
- Proceed as follows:
 - Short circuit the medium voltage bushings (U-X or H1-H2).
 - Short circuit the low voltage Bushings (u-Pn-x or x1-x2-x3).

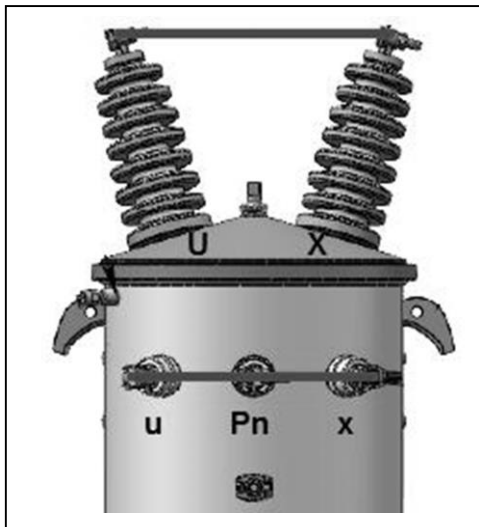

Figure 47: Short circuit of medium and low voltage Bushings

- To carry out the different measurements (3) the cables are connected as follows:
 - MV-LV: Power cable (+) in MV and black cable (-) in

LV, the reference cable in a ground terminal.

- MV-Grd: Power cable (+) in MV and black cable (-) in Grd, the reference cable in LV.
- LV-Grd: Power cable (+) in LV and black cable (-) in Grd, the reference cable s in MV.

➤ Results analysis

This test has no correspondence between the nominal power value, the transformer voltage and the insulation resistance, which is why the minimum values are left to the discretion of the manufacturer.

To verify if the values measured at the installation site are in accordance, keep in mind the following criteria:

- Compare the results obtained against those reported by MAGNETRON SAS in the test certificate, these should be very close to or above what was measured at the factory.
- Take into account the minimum values established by MAGNETRON SAS according to the class of the transformer.
- Apply James Biddle's empirical formula to calculate the



minimum value of insulation resistance:

Class (kV)	Minimum resistance (MΩ)
1.2	1,000
15	10,000
34.5	50,000

$$R = \frac{CE}{\sqrt{kVA}}$$

R = Resistance at 20°C of the insulation measured in 1 min
 C = Constant for measurements at 20°C
 C= 1.6 for transformers in oil
 C= 30 for dry transformers
 KVA= rated power
 E= Rated voltage in volts of the winding under test

Caution: If you have any questions or think that water has entered in the transformer, contact MAGNETRON SAS

12.2.4 Insulating liquid tests

The tests on the insulating liquid must be carried out when:

- The insulation resistance results do not meet the criteria.
- Doubts arise due to the possible presence of water (moisture).

The tests on the insulating liquid are carried out to determine the conditions of the same, ONLY with satisfactory results, the transformer can be energized.

The minimum tests required are:

12.2.4.1 Dielectric strength

This test measures the ability of the insulating liquid to withstand tension without failing.

Dielectric breakdown voltage is used to indicate the presence of contaminants such as water, dirt, or conductive particles in the fluid, one or more of which may be present in significant concentrations when low breakdown voltages are obtained.

12.2.4.2 Water content

This test method covers the measurement of water present in the insulating liquid by coulometric Karl Fischer titration.

The electrical characteristics of an insulating liquid can be negatively affected by excessive water content. A high water content can make a liquid insulating may not be suitable for some electrical applications due to deterioration of properties such as dielectric breakdown voltage.

12.2.4.3 Color

This test method covers the visual determination of the color of a wide variety of petroleum



products, such as lubricating oils, heating oils, diesel fuel oils, and petroleum waxes.

Using a standard light source, a liquid sample is placed in the test container and contrasts against colored glass disks ranging in value from 0.5 to 8.0. When an exact match is not found and the sample color falls between two standard colors, the larger of the two colors is reported.

12.2.4.4 Aspect (visual)

The insulating liquid should be optically clear in appearance to allow visual inspection inside the equipment tank.

When the insulating liquid presents a change in its appearance, it is an indication of oxidation, deterioration or contamination, product of the corrosion of metal or other undesirable materials.

12.2.4.5 Other tests

Other tests that can be performed on the insulating liquid to confirm its status are listed below:

- Interface tension
- Specific gravity
- Disable number
- Power factor
- PCB's content
- Viscosity
- Corrosive sulfur

These tests should be done when any of the following situations occurs:

- When the results of the minimum required tests are very close to the minimum or maximum allowed.
- By request of MAGNETRON SAS
- By customer request.
- At the request of an external entity.

12.2.4.6 Reference values

- Mineral oil

Method and test	Reference value
Dielectric strength ASTM D1816	$\geq 35\text{kV}$
Water content ASTM D1533	$\leq 35\text{ppm}$
Color ASTM D1500	≤ 0.5
Aspect ASTM D1524	Clean and clear

➤ Vegetable oil

Method and test	Reference value
Dielectric strength ASTM D1816 1mm gap 2mm gap	 ≥ 20kV ≥ 35kV
Water content ASTM D1533	≤ 200ppm
Color ASTM D1500	≤ 1.0
Aspect ASTM D1524	Clear and bright

Note: Any deviation from the tests and reviews listed in this section must be notified to MAGNETRON SAS in order to receive instructions on how to proceed and not put the transformer at risk. Failure to do so will result in the loss of the warranty.

13. Installation and commissioning

Caution: For Colombia, the installation of the transformer must be done according to the requirements of the technical standards NTC-2050, NTC-3582 and the technical regulation of electrical installations (RETIE).

For other countries, the rules or laws that apply to them must be followed.

The installation of the transformer is not the responsibility of MAGNETRON SAS (unless otherwise specified in the contract), however, as an interested party that the product fulfills its function in the best conditions, the following considerations must be followed:

13.1 Pole mount

- Substations with pole transformers can be installed, without any type of enclosure, as long as it does not exceed 250 kVA or 800 kgf, taking into account the following:

Power (kVA)	Max weight (kgf)	ONE POST min breaking strength (kgf)
≤112.5	600	510
112.5 < kVA = 150	700	750
150 < kVA = 250	800	1050

- The use of double pole structures for the installation of transformers should be avoided, since they generate greater visual impact and discomfort in mobility.
- In rural installations or small houses, transformers up to 25 kVA can be installed on wooden poles with a breaking resistance less than or equal to 510 kgf.
- All pole-type substations must have overcurrent and overvoltage protection (DPS) on at least the primary side of the transformer.
- The DPS should be installed as close as possible to the primary bushings (+/- 50 cm).
- The transformer fixing elements must support at least 2.5 times its weight.
- The transformer, when fixed to the pole, must be left with an inclination of $90^\circ \pm 2^\circ$.

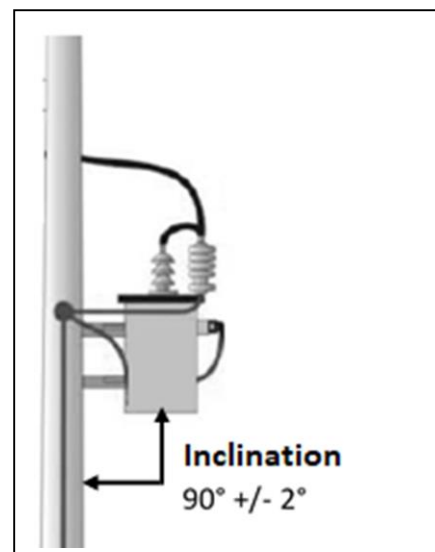

Figure 48: Inclination Degree

Caution: An inclination degree outside the specified limit causes energized parts to remain outside the level of the insulating liquid, causing a jump between them or damage to the transformer.

13.2 Grounding system

- The low voltage neutral point, the tank and the DPS must be solidly grounded.

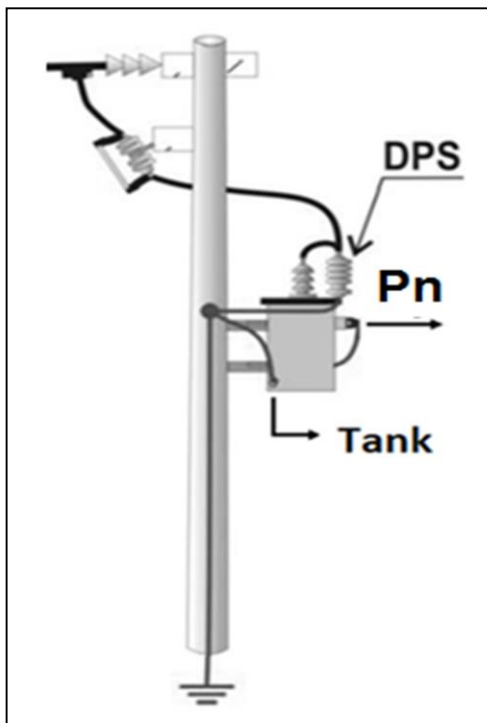

Figure 49: Grounding system

- The grounding system has the following objectives:
 - Guarantee the safety of living beings.

- Ensure the protection of facilities.
 - Electromagnetic compatibility.
 - Allow protection teams to quickly clear faults.
 - Serve as a common reference to the electrical system.
- Reference values for the grounding system.

Application	Maximum values of grounding resistance (Ω)
Structures and metallic turrets of lines or networks with guard cable	20
High and extra high voltage substations	1
High voltage substations	10
Lightning protection	10
Low voltage connection neutral point	25
Networks for electronic or sensitive equipment	10



13.3 Connection sequence

- Make all connections to the grounding system.
- Make the LV connections.
- Make the MV connections.

Caution: The connections cannot be stressed. The medium voltage ones must have a shape and mechanical rigidity that does not allow them to move with the wind or vibrations, in such a way that they come into contact with parts that should not be energized or approaches that produce electric arcs.

13.4 Commissioning

Caution: To energize the product, it must be guaranteed that the tests and revisions listed in number 12 of this manual gave compliant results; otherwise, the energization cannot be carried out and you must contact MAGNETRON SAS personnel to receive instructions.

Also, remember to use the appropriate tools and protections, such as: Pole, dielectric gloves, rubber boots, etc.

- Once the transformer is installed, leave it at rest for a minimum of 4 hours for transformers with mineral oil and a minimum of 6 hours for transformers with vegetable oil.

- Energize the transformer at no load (no load).
- Make sure that the transformer does not produce abnormal noises (humming, crackling, flickering, etc.).
- Check the output voltage and check that is balanced and within what is required.
- Gradually install the load and keep checking the output voltage.
- After all the load is installed, observe the operation of the transformer for several hours.
- Keep a written record of the final installation conditions.
- Clean and order the work area.

13.4.1 Energizing transformers with vegetable oil at temperatures below -20°C

Caution: For no reason activate the mobile components (disconnecter, tap changer switch, magnex, breaker, etc.) before or shortly after their energization.

The C57.12.00-1993 standard considers that initial temperatures below -20 °C are unusual service.

The energization of transformers immersed in vegetable oil at temperatures below -20°C, can follow the



same sequence as transformers immersed in mineral oil, as long as the following criteria are met:

- Store transformers in such a way that no mechanical movement is required to energize the transformer (ie: disconnect switch in CLOSE position, tap changer anchored in work position, etc.), taking this approach, no mechanical movement should be required. mechanical movement to energize the transformer.
- Do not activate mobile components (disconnect, switch, magnex, breaker, etc.) before or shortly after energizing; in extreme temperature conditions, the insulating liquid becomes more viscous (begins to thicken and, over time, may gel), hindering the mechanical maneuvering of the components and extinguishing electrical arcs more slowly.
- Energize the transformer empty (no load), keep it like this for a minimum of 18 hours.

Note: Monitor the temperature of the insulating liquid, until it is above room temperature.

- Gradually connect the load.
- After all the load is installed, observe the operation of the transformer for a while.
- To change an internally damaged component (a BAY-O-NET fuse, for example), when the ambient temperature is below -30°C, the transformer must be externally heated to make the vegetable oil more liquid.

For more information, you can consult the following standards:

- C57.12.93, C.57.106 and C.57.12.00.

Or, the guidelines of Cargill, supplier of vegetable oil (FR3):

- G2200S “Transformer Repair Guide”.
- G2300S “Guide for storage, installation, commissioning and maintenance of transformers immersed in FR3 fluid”.
- R2120 “Cold Start Recommendations for Envirotemp FR3”.



13.4.2 Energizing transformers with mineral oil at temperatures below -20°C

The C57.12.00 standard considers initial temperatures below -20°C to be unusual service.

For starting temperatures below -20°C , energize the transformer and keep it without load for a minimum of 12 hours.

Dielectric fluids can exhibit a drop in dielectric strength at lower temperatures if moisture precipitates. If, at any temperature, the density of the insulating liquid is greater than the density of water, free ice or free water could exist in the system and cause dielectric discontinuity and possible failure.

Any extremely cold transformer should be energized with no load and then gradually increase the load.

Temporarily, localized temperatures may exceed normal values.

These transient conditions are easily tolerated by a properly designed transformer.

At very low ambient temperatures, it will take some time before external radiators

are effective, but at these low temperatures, additional cooling should not be necessary.

Never energize a transformer with mineral oil with temperatures under -40°C Celsius, this represents a big risk of failure, the transformer must be heated by external elements before energization.



14. Transformers with two or more months in storage

If the transformer has been stored for a period equal to or greater than two months, without being energized or since its last energization, the following procedure must be followed:

- Perform the tests described in this guide, from 12.2.1 to 12.2.4.5.
- If and only if the results are satisfactory, proceed as follows:
 - ✓ Energize the transformer without load, for a minimum of 4 hours for mineral oil transformers and a minimum of 6 hours for vegetable oil transformers.
 - ✓ Once the minimum energizing time without load has expired, connect the load.
- Once the load is installed, periodically check the operation of the transformer.
- Keep a written record of the final installation conditions.
- Clean and order the work area.

If during the execution of the tests described in this guide, from numeral 12.2.1 to numeral 12.2.4.5, you

encounter any inconvenience, take into account the recommendations in the table below:

Note: If the inconvenience(s) persist(s), do not intervene the transformer and contact MAGNETRON SAS



Inconvenience presented	Does not give transformation ratio	It does not give resistance of the windings in MV	Very low insulation resistance	Short in insulation resistance	Insulating liquid does not meet the criteria
What to review?					
Check condition of measuring equipment and cables	X	X			
Check correct interlocking of the switch	X	X			
Check connection of the TTR to the transformer, according to the connection group,	X				
Check measuring equipment, that it is in the correct range		X			
Cleaning of MV and LV Bushings			X		
Test temperature			X		
Correction results by temperature			X		
Check that the neutral point is disconnected from earth				X	
If it has an electrostatic screen, it must not be grounded.				X	
Review sampling process					X
Take a second sample to validate results					X
Take sample when the no-load energization time has elapsed					X



15. Maintenance

Caution: If it is not carried out and evidence of the execution of preventive maintenance, it will cause the loss of the guarantee.

Caution: To intervene on the transformer, disconnect the MV and LV voltage sources in order to put it out of service.

Disconnect the MV terminals, short them and connect them to the grounding system.

Disconnect the LV terminals, short them and connect them to the grounding system.

Delimit and mark the work area.

The transformer is an electrical machine designed and manufactured to function 20 years or more under normal conditions of use.

The owner of the transformer is responsible for inspecting, maintaining and keeping it in good condition.

To help you for this purpose, the following must be followed instructions:

15.1 Preventive maintenance

➤ During the warranty period, report all failures or

eventualities to MAGNETRON SAS

➤ Once a year, you must inspect the transformer, verifying the following:

- Condition and cleanliness of the tank.
- Condition and cleanliness of the MV and LV Bushings.
- Condition and cleanliness of the lightning rods (DPS).
- Condition and cleanliness of the packaging.
- Condition and cleanliness of the overpressure valve.
- Adjustment of the connections.
- Paint condition.
- Confirmation that there are no leaks of the insulating liquid.
- Operation and correct interlocking of the derivation switch.
- Condition and adjustment of the accessories for ground connections.

- Condition, cleanliness and operation of the other control or protection accessories.
- Tilt of the pole.

15.2 Corrective maintenance

- During the warranty period, report all failures or eventualities to MAGNETRON SAS, for any reason whatsoever, do not intervene on the product.
- For interventions outside the warranty period, contact MAGNETRON SAS or use a specialized transformer workshop.

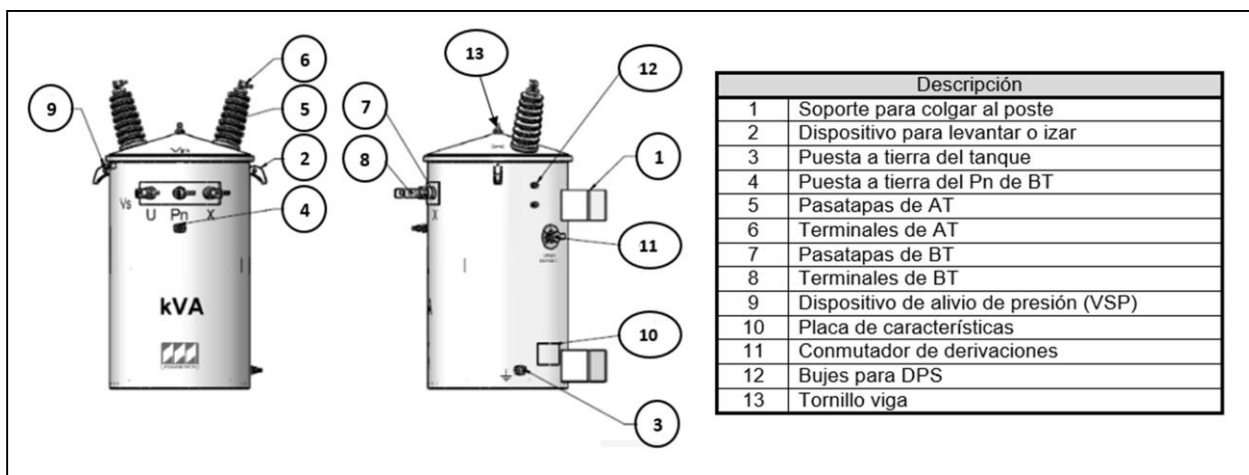

Figure 50: External parts of the transformer



16. Repair

- The owner of the transformer is responsible for inspecting, maintaining and keeping it in good condition.
- During the warranty period, report all failures or eventualities to MAGNETRON S.A.S. for any reason whatsoever, do not repair the product without prior written authorization.
- All repairs under warranty must be done by MAGNETRON SAS or an authorized service workshop.
- For repairs outside the warranty period, contact MAGNETRON SAS or use a specialized transformer workshop



17. Problems and possible solutions

- Remember to fully comply with the numerals of “Review and tests before installation” and “Installation and commissioning” (numerals 12 and 13).
- The adjustment of the accessories must be done with a torque wrench, applying the torques listed in number 18 “Adjustment torques”.
- Adjustment of accessories is done externally only, for internal adjustments please contact MAGNETRON S.A.S. or with an authorized workshop.

Inconvenience presented	Expels the canuelas	Blow the fuses	Voltage difference between LV phases	It does not give voltage output in LV	Insulating liquid stain on the VSP	Insulating liquid stain on accessories
What to review?						
Connection of the transformer to the MV line	X			X		
Lightning rod state	X					
Lightning rod characteristics	X					
Energize no load	X	X				
Check condition of fuses		X				
Check that the fuses are correct (amperage)		X				
Correct landing of the transformer (tank)		X	X			
Correct landing of the Pn			X			
Check wiring connection settings			X	X		
Clean and monitor if persists					X	X
Check tightening torque (externally)					X	X
Check input voltage				X		
Check input voltage		X				
Correct anchoring of the commutator				X		
Test the transformer	X			X		

Inconvenience presented	Does not give transformation ratio	It does not give resistance of the windings in MV	Very low insulation resistance	Short in insulation resistance	Insulating liquid does not meet the criteria
What to review?					
Check condition of measuring equipment and cables	X	X			
Check correct interlocking of the switch	X	X			
Check connection of the TTR to the transformer, according to the connection group,	X				
Check measuring equipment, that it is in the correct range		X			
Cleaning of MV and LV Bushings			X		
Test temperature			X		
Correction results by temperature			X		
Check that the neutral point is disconnected from earth				X	
If it has an electrostatic screen, it must not be grounded.				X	
Review sampling process					X
Take a second sample to validate results					X
Take sample when the no-load energization time has elapsed					X

18. Tightening torques

The different adjustments that are made in the external accessories of the transformer, should be to do following the recommendations of the suppliers regarding torques and sequence of adjustment. The most relevant are listed below:

18.1 Screws in general



Torque (lbf * ft)						
Iron			Stainless steel			
Diameter	Grade 2	Grade 5	Grade 8	Diameter	A304	A316
1/4	5,5	8	12	1/4	6	7
5/16	11	17	25	5/16	11	12
3/8	20	31	44	3/8	20	21
7/16	32	49	70	7/16	31	33
1/2	49	75	107	1/2	43	45
9/16	70	109	154	9/16	56	59
5/8	97	150	212	5/8	92	96
3/4	173	266	376	3/4	127	131
7/8	166	429	606	7/8	194	202
1	250	644	909	1	286	299
1-1/8	354	794	1287	1-1/8	413	432
1-1/4	500	1120	1875	1-1/4	523	546
1-3/8	655	1469	2382	1-1/2	888	930
1-1/2	870	1950	3161			

Note: The tightening torques in the table correspond only to the screws, w used to hold accessories (porcelain, polymers, etc.) the tightening torque is defined by the material.

18.2 Adjustment screw Cover-Tank

Tank diameter (mm)	Torque (lb ft)	Beam screw
312	18	Short
345	21	
370		
406	28	
442	32	
478		
514	34	Long
550		
586		

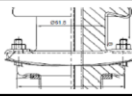

18.3 MV and LV bushings

Product	lbf * ft	Image
MT spider nut	70	
BT spider nut	29	
BT aluminum nut	35	
Stud adjustment to connect MT	18	
Anchor adjustment 7 mm to 11.9 mm	13	
Anchor adjustment 12 mm to 16 mm	15	
Anchor adjustment 19 mm to 32 mm	19	
Bolt adjustment for external clamping flanges	12	

18.4 Tap changer

Accessory	lbf . ft	Image
SWITCH nut	8 to 9	

18.5 Overpressure valves

Overpressure valve	Tightening torque	Image
1/4"	20 to 25	
1/2"	54	
3/4"	83	
1-1/4"	121	



19. Environment

MAGNETRON S.A.S. is a company committed to the environment, for this reason, our transformers meet all the requirements related to the subject.

MAGNETRON S.A.S. has identified potential risks that may cause harmful environmental effects on the environment.

MAGNETRON S.A.S. itself provides its clients with a series of environmental advice, in order to prevent and minimize contamination throughout the life cycle of the transformer.

The environmental councils are consigned in the environmental management plan, made up of 5 environmental management programs.

If you want to know more about environmental programs, contact MAGNETRON S.A.S.

The final receiver of the transformer must comply with current legislation and that applies to it.

In the event of leakage of the insulating liquid, it must be collected in a container, avoid it falling on the ground.

- If insulating liquid has been spilled on the floor, clean it up with an absorbent material (example: sawdust).

- The insulating liquid that has been collected and the media used for cleaning must be treated as toxic and hazardous waste.
- Waste should not be mixed.

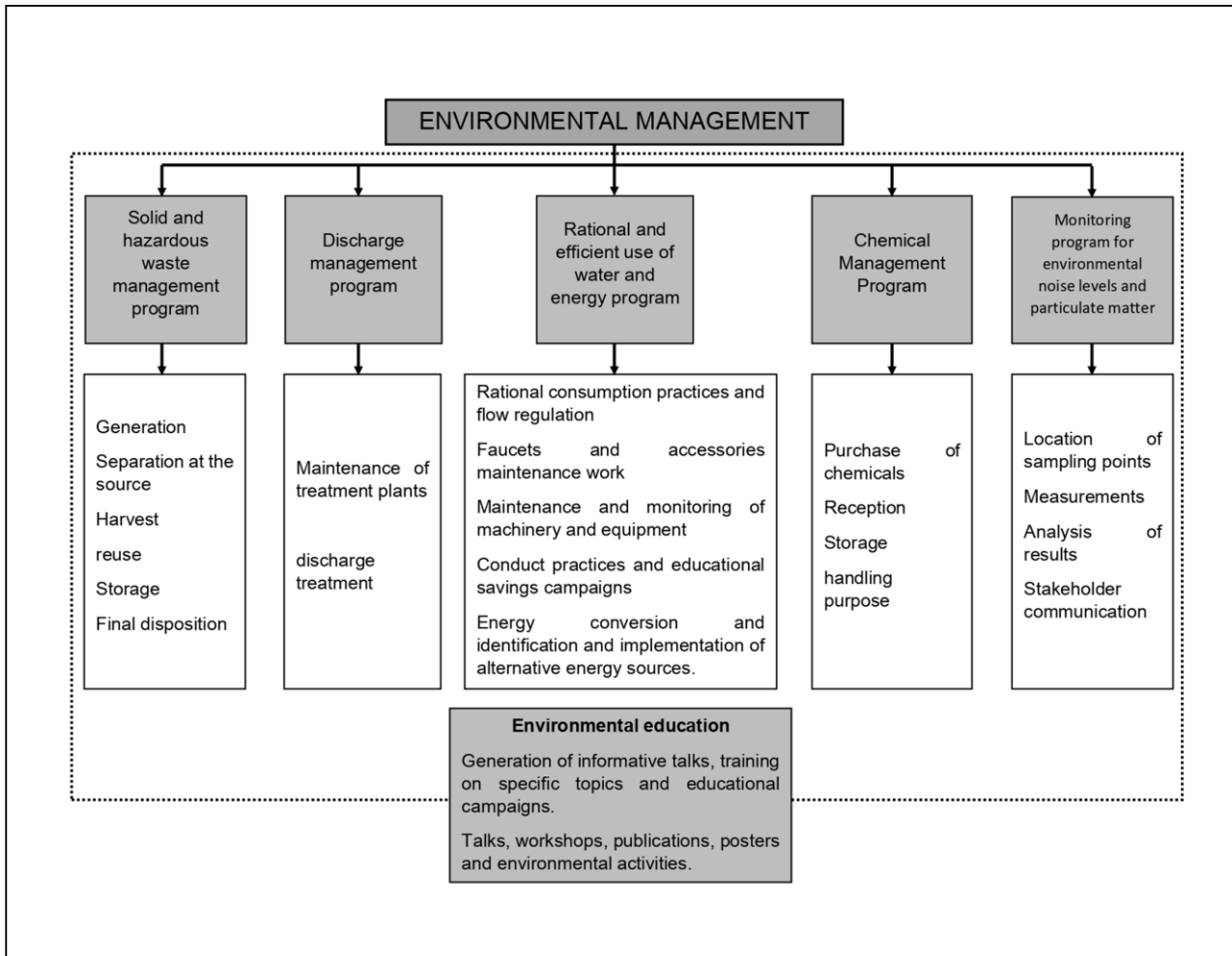

Figure 51: MAGNETRON S.A.S. Environmental Management Plan



20. Warranty terms and conditions

Refer to the guarantee certificate that is delivered with each product; behind it, there are the instructions that must be followed to make the guarantee effective and the conditions that invalidate it.



21. Contact Us

For more information or to provide technical support, contact us through the following means:

	servicioexterno.magnetron.com.co
	customerservice.magnetron.com.co
	(57) 3187117456 (57) 3157100 extension 101